

**OREGON OCCUPATIONAL SAFETY AND HEALTH DIVISION
DEPARTMENT OF CONSUMER AND BUSINESS SERVICES**

PROGRAM DIRECTIVE

Program Directive A-212

Issued: January 2, 1996

Revised: August 21, 2003

SUBJECT: Electric Power Generation, Transmission, and Distribution Facilities.

AFFECTED

CODES: Division 2 1910.269

PURPOSE: This guide provides inspection assistance related to 1910.269 and a glossary of industry terms to assist OR-OSHA staff performing inspections at electric power generation, transmission, and distribution facilities.

SCOPE: This instruction applies OR-OSHA-wide.

ACTION: Field Office Managers will ensure that OR-OSHA staff performing inspections or consultations or consultations at electric power generation, transmission, and distribution facilities are aware of these guidelines and follow them when appropriate.

INSPECTION

RESOURCES:

1. Experienced Personnel Only The Manager of Enforcement will ensure that an adequate number of appropriately trained and/or experienced SCO/HCOs are available for inspections at electric power generation, transmission and distribution installations.
2. Minimum Training The minimum training requirements for all OR-OSHA staff who inspect, or consult at an electrical power generation, transmission, and /or distribution facility, or other site covered by 1910.269 are:
 1. Completion of the Electrical Power Generation, Transmission, and Distribution OSHA Technical Institute (OTI) Course #319: or
 2. Equivalent electrical-safety training, provided jointly by OR-OSHA and an electrical utility(s). Topics, such as process

terminology, controls, personal protective equipment, hazards, appropriate application of 1910.269, and other related electrical standards must be included in the training. The course must also include “hands-on” learning activities, and/or accompanying utility safety personnel as they evaluate the safety and health of facilities and job sites.

3. Availability of Personnel In field offices where adequate numbers of appropriately trained and/or experienced OR-OSHA staff are unavailable for inspections and consultations, management may obtain assistance from other field offices in making such personnel available.
4. Expert Services When they are considered necessary, expert services will be used in the case at the earliest practicable date.

**OR-OSHA
STAFF SAFETY**

AND HEALTH: The following safety and health concerns for OR-OSHA staff, are applicable during compliance inspections or consultations at electric power generation, transmission, and distribution facilities.

5. Electrical Hazards. Due to the fact that electrical hazards are normally not observable, OR-OSHA staff are reminded to take caution when approaching utility employees working with machinery or electrical equipment so as not to interrupt them prior to determining that it is safe to do so. Due to the presence of open bus bars and other energized equipment in this industry, OR-OSHA staff should take caution not to touch anything unfamiliar to them.

Only OR-OSHA staff who have received the required minimum training, and who are accompanied by qualified persons may enter restricted areas in generation plants or substations. Examples of restricted areas are: electrical vaults, switch gear rooms, switch yards, transformer rooms, chlorine system enclosures, and water or steam spaces.

6. Chemical and Atmospheric Hazards. OR-OSHA staff are to inquire about the presence of gases, fumes and vapors, and the location of high pressure steam lines, for their own protection as well as that of facility employees. (OR-OSHA staff should have available, if needed, a detector tube pump and a supply of detector tubes for air contaminants they may encounter.) Examples of situations where such hazards may exist are:

1. Furnace effluents containing particulate, coal tar pitch volatiles, sulphur dioxide and carbon monoxide may be present. The latter two may be present in lethal concentrations near furnace leaks. (A clue to the constant presence of sulphur dioxide is corroded metal structures/surfaces.) In addition, particulate from flash contain silica, and possibly arsenic, depending on the type of coal used;
2. Ozone is produced in some high voltage electrical operations. For example, it may be present in high concentrations in the electrostatic precipitator;
3. Enclosed spaces may contain traces of metal fumes and organic vapors emanating from energized equipment;
4. During the chemical cleaning of boilers and pressure vessels, flammable liquids, gases, vapors or combustible materials may be used or produced during the cleaning process. Hydrazine may be used to clean boilers. Hydrazine has a PEL of 1 ppm and may be absorbed through the skin;
5. Chlorine is likely to be present in chlorine system enclosures and may be present in the surrounding area. As a consequence of water treatment, there may be hazardous toxic or reactive chemicals in drainage trenches in the lowest levels of the power plant; and
6. High pressure steam leaks which may be invisible are hazardous energy sources. The noise in the generation area may conceal such leaks. Exposure to such hazards could be fatal. For example, steam from a pinhole leak could lance completely through the body of a person. Experienced employees travel in these areas with a rag tied onto a stick held in front of them to detect such steam hazards.
7. Other Potential Hazards.
 1. Chrysotile asbestos is present in older power generation facilities. Amosite asbestos may be in use in valve packing.
 2. During overhaul of boilers, the use of scaffolding and boatswain chairs may present fall hazards. OR-OSHA staff should evaluate such fall hazards, particularly in the expansion spaces between the boilers and gratings.

3. Because of extremely high temperatures, looking into the flame of a boiler may cause eye damage due to electromagnetic radiation in the optical range if protection is not used.
 4. Slag may be mechanically removed from fireside, such as tubes, surfaces of boilers. Protection from falling slag and other objects is required by 1910.269(v)(9)(i). Appropriate personal protective equipment must be used to supplement engineering controls and safe and healthful work practices to prevent harmful exposure to such hazards.
 5. Areas where pulverized coal is transported and stored may contain explosive coal/air mixtures. Electric equipment in such area must be approved for the hazardous location. The location of a safe means of egress must always be kept in mind.
 6. A fossil-fuel power plant should have a properly trained and outfitted fire brigade.
 7. Mercury may be present in the flooring of the instrument repair area of the power plant.
 8. There are noise hazards related to induction fans.
 9. Electrical test equipment used by OR-OSHA must be fully protected against the effects of electromagnetic fields.
 10. Cadmium may be used to coat fish-screens in the intake caissons and to tip blades used to propel coal.
 11. Polychlorinated biphenyls may be present in maintenance operations involving capacitors and transformers. Dioxin may be present where these components were overheated.
8. Personal Protective Equipment (PPE).
1. To set an example, OR-OSHA staff must wear clothing, in addition to standard PPE, made of flame resistant or flame retardant (FR) clothing. Except in unusual circumstances, OR-OSHA staff are not to wear specialty PPE designed for protection from exposure to electrical hazards (see paragraph 5.d.(2) below).

2. When in power generation plants, OR-OSHA staff must use polycarbonate or cruzite safety glasses, with side shields (or the equivalent) to provide protection from flashover. Nonfogging spray applications may be used to keep glasses clear.
 3. When working in environments with elevated temperatures, such as boiler rooms, OR-OSHA staff are encouraged to consume plenty of water.
 4. Properly sized work gloves should be worn to prevent injury when touching or grabbing hot or gritty surfaces or objects in the power plant.
9. Special Precautions When Obtaining Photographs and Recordings.
1. Documentation of worksite conditions and equipment during the walk around inspection can normally be conducted at a distance using cameras with telephoto lenses. Cameras used in hazardous (classified) locations must be intrinsically safe.
 2. Only OR-OSHA staff who have received the required minimum training, and who are accompanied by qualified persons may enter restricted areas in generation plants or substations. Examples of restricted areas are: electrical vaults; switch gear rooms, switch yards, rooms, chlorine system enclosures, and water or steam spaces
 3. Consult with qualified onsite personnel and determine how to obtain necessary documentation including photographs and recordings from restricted areas safely. In some situations, detailed sketches may be more appropriate than photographs/videos. Qualified on-site personnel will be able to draw sketches themselves as part of interview statements obviating the need, in some cases, for anyone to enter restricted areas for documentation purposes.
 4. On site personnel should not be asked to make inspection photographs/videos for the OR-OSHA staff.
 5. If it becomes necessary for an OR-OSHA staff member to enter a restricted area, special precautions must be taken, as follows:

1. Obtain from the employer information about the hazards in the area, steps taken to eliminate the hazards, and recommendations on precautions to be taken to safely enter the area;
2. Obtain and use necessary equipment;
3. A qualified person or (employer) designated person must accompany the OR-OSHA staff member into the restricted area; and
4. Comply with the 1910.269 requirements applicable to qualified person for entry into such spaces.

SOURCES FOR

TRAINING: The following are sources for training:

10. OSHA Training Institute;
11. Utility companies;
12. Trade unions;
13. Trade associations; and
14. Apprenticeship programs.

INFORMATION ABOUT THE FACILITY:

15. General Information OR-OSHA staff should consider general information about the facility, including size, layout, who built it, sources of incoming energy, maximum energy output, types and specifications of utilization equipment, method(s) of power generation (if applicable), maximum voltages developed, maximum amperes transmitted, maximum capacities of lines, location of PPE and tools, person(s) responsible for maintaining and testing the PPE and tools, etc.
16. Specific Information Consider as much specific information as possible about the areas of the facility to be visited, including but not limited to: job titles of the employees (such as power line workers in power transmission inspections; and maintenance electrician, watchmen boiler end, watch electrician and firemen in power generation plant inspections) and

nomenclature of the equipment involved in the operations to be inspected; specific normal operating voltage, ampere and ohm/resistance/reactance/resistivity ranges of the equipment; potential maximum peaks of amperes and voltages in abnormal situations; and maximum rated capacities of the equipment.

NOTE: During the walkaround additional information may be obtained by observing signs, labels, equipment markings, nature of walking/working surfaces, vertical and overhead structures, etc., as well as questioning, and listening to, members of the walkaround party and other employees.

17. Oregon Public Utility Commission Assistance. Because many of the procedures that may be encountered are based on standard work practices, it may be necessary to consult with the Electrical Safety Section of the Oregon Public Utility Commission. This will enable the OR-OSHA staff member to be able to determine, as necessary, if the facility is conforming with respective safety-related practices.

REFERRALS: Field Office Managers will coordinate their inspection and hazard abatement activities with MSHA and/or Nuclear Regulatory Commission field Offices, when appropriate, to ensure the safety of affected employees. Referrals of hazards shall be made as appropriate.

18. MSHA The requirements in 1910.269 are intended to apply to conditions and installations for which MSHA does not "exercise statutory authority to prescribe or enforce standards or regulations. MSHA's jurisdiction, relative to power generation plants, covers the processing of coal prior to final transport of the coal into the power generation building (where the coal is burned). Processing includes activities such as mixing, breaking, crushing, sizing, washing, and mechanically assisted drying. The location of these activities, whether on or off the property, owned or leased by the power generation company, is not an issue. The following two scenarios are provided to assist in understanding the MSHA/OR-OSHA interface:
 1. Coal is stored outside in piles on the property of a power generation company. Before use, the coal is run through a crusher building. Then it is sized, washed, artificially dried as being transported on a conveyor, then dumped into the power generation building. In this scenario, MSHA has jurisdiction up to the point where the processed coal is dumped onto the conveyor which carries it into the power generation building; and

2. Coal is stored outside the power generation building in silos, hoppers or outdoor piles, on company property and immediately next door on property not belonging to the power generation company. The power generation company has the contractual right to transport and use the coal in its facility. The coal is not processed in any way before use. It is loaded from the various storage areas on both properties onto conveyors, which deliver it directly into the power generation building. OR-OSHA has jurisdiction over all of the activities described in this scenario, including the silos, hoppers and outdoor piles.

NOTE: Because the above information may not be sufficient to delineate jurisdictional boundaries in many situations, it is recommended that the SCO/HCO consult with the local MSHA office to get a consensus on jurisdiction during each inspection where this issue may be a factor.

19. Nuclear Regulatory Commission. Both the NRC and OR-OSHA have jurisdiction over occupational safety and health at NRC-licensed facilities, many of which are electric power generation plants fueled by nuclear energy. At such facilities OR-OSHA covers plant conditions which result in occupational hazards, but which do not affect the safety of the licensed radioactive material. For example, OR-OSHA covers exposures to toxic non-radioactive material and other non-radioactive related hazards throughout the facility. Specifically, 1910.269 applies throughout such facilities except in areas directly involved in the support and/or the production of nuclear energy.

**CONSTRUCTION
VS
MAINTENANCE:**

20. Definition of Construction. A general definition of "construction" is given at 1910.12(b) as follows: "For purposes of this section, Construction work means work for construction, alteration, and/or repair, including painting and decorating."
21. Examples. Examples of situations in which the question of construction or maintenance may arise are:
 1. Erection of new power lines and towers, construction of generation plants and power stations, installation of underground distribution facilities, and additions or extension to existing equipment or lines is construction;

2. Moving an existing power line and supporting poles, without alteration or replacement of parts, a few feet to the side to allow for the widening of a roadway is covered under 1910.269. If there were violations, the company moving the power lines in this scenario would be cited under 1910.269. Subdivision V. A contractor working on the roadway would be cited under Division 3. If further down the road, longer power lines had to be installed to cross the widened span of the roadway, then this operation would be construction, covered under Division 3, Subdivision V;
 3. Generally speaking, refurbishing (replacement by identical or similar parts) equipment and space is maintenance and is covered under 1910.269. Reconfiguration of space or installation of different or upgraded equipment (such as increasing load-carrying capacity is construction;
 4. Scheduled touch-up and spot painting which is done to maintain equipment or structures is maintenance, while painting a newly built structure is construction. A complete repainting job in one room or on a major portion of a structure or building is construction (Note: Painting is not covered by 1926, Subdivision V). Removal of lead-based paints is construction; and
 5. The repair of specific limited portions of electrical systems to keep them in operation is covered by Division 2.
22. Citation in the Alternative. In cases where it is not readily obvious whether Division 2 or 3 apply, citation of standards from both standards should be issued to address each identified hazard, with emphasis on the more protective standard.

**OTHER
RELATED**

STANDARDS: OR-OSHA's 1910.268 pertains to telecommunications work. Much of the field work related to 1910.268 is similar in nature to the type of field work performed by electric utility employees, and the hazards faced in the performance of this type of work are frequently the same in both industries. Determining which standard applies is based on the activity being performed by the employee(s).

APPENDIX E: Appendix E to 1910.269 provides a list of references that can be helpful in understanding and complying with the requirements of 1910.269. For example, Division 2, Subdivision R, OAR437-002-0301, Oregon Rules

For Tree And Shrub Services provides information related to line-clearance tree-trimming.

APPENDIX A

GLOSSARY OF INDUSTRY TERMS

Air gap withstand voltage means a voltage which corresponds to a 1 in 1000 probability, approximately, of flashover as determined by the statistical method described in Appendix B, paragraph IV.A.4. of the standard.

Ampacity means the current-carrying capacity of electric conductors expressed in amperes.

Anchorage means a secure point of attachment for personal fall arrest equipment which is independent of the means of supporting or suspending employees.

Applied loads means the working loads to which mechanical equipment are subjected when lifting and/or moving lines or other materials.

Atmospheric pressure or temperature differences means the differences between the pressure or temperature inside, relative to the temperature or pressure outside an enclosed space

AWG stands for American Wire Gauge (Also called Brown and Sharpe gauge). AWG refers to wire size that is the diameter of a wire.

Backfeed means energizing an otherwise de-energized circuit by a power source other than the de-energized power source.

Body belt (safety belt) means a strap with the means both for securing it about the waist and for attaching it to a lanyard, lifeline, or deceleration device.

Body harness means a design of straps which may be secured about the employee in a manner to distribute the fall arrest forces over at least the thighs, pelvis, waist, chest and shoulders with means of attaching it to other components of a personal fall arrest system.

Bonding means the joining of conductive parts to form an electrically conductive path designed to maintain a common electrical potential.

Breakdown voltage means the voltage at which a disruptive discharge takes place through or over the surface of insulation.

Brush means a conductor, usually composed, in part, of some form of the element carbon, serving to maintain an electric connection between stationary and moving parts of a machine or apparatus.

Buckling means a lateral deflection. For example a power or telephone pole which deflects in a horizontal direction, that is perpendicular to the length of the pole, such that the pole is howed relative to its ends.

Bushing means an insulating structure including a central conductor, or providing a passageway for such a conductor, with provision for mounting on a barrier, conducting or otherwise, for the purpose of insulating the conductor from the barrier and conducting current from one side of the barrier to the other. (See ANSI/IEEE Std. 100-1988, IEEE Standard Dictionary of Electrical and Electronic Terms for other definitions of bushings used in electric power generation, transmission and distribution).

Capacitor is an electrical device which stores an electrical charge. It consists of two conducting plates of metal separated by an insulating material called a dielectric. Capacitance (C) is the ability to store an electrical charge where $C=Q/V$ and Q is the amount of charge and V is voltage. The unit for capacitance is the Farad (F).

Capacitor bank is a group of electrically connected capacitors. A capacitor bank is used to raise the power factor that is, it tends to bring the voltage and current in phase. When the voltage and current are perfectly in phase, the power factor is unity (one).

Catch-off point means an attachment point on supporting structures to which load bearing hardware and accessories, rigging and hoists are attached to install or remove line conductors.

Circuit transient means a change in the steady state condition of voltage or current or both. It is the transition period during which the current and voltage change from their former value to new ones. This transition interval is called the transient; before and after which, the circuits are said to be in the steady state condition. Transients may be caused by lightning, by faults, or by switching operations and may be transferred readily from one conductor to another by means of electrostatic or electromagnetic coupling.

Climbers are a pair of hooked shaped devices which are used by an employee to ascend, maintain working positions and descend wooden poles. Climbers are worn over the work shoes such that the curved part of the hook fits under the shoe between the heel and sole and the stem of the hook fits against the inside of the lower leg. Climbers are strapped on the leg below the knee and on the foot at the ankle.

Closed circuit means an unbroken conductive path for current to flow from the electromotive force (emf) through loads and back to the emf source.

Coal bunker means an open bin in which coal is stored. A bunker has a four sided cross section; whereas a coal silo, also used to store coal, has a circular cross section.

Cogeneration means two or more power generating stations supplying electrical energy to the same distribution transmission system.

Condenser means a heat exchange where latent heat is removed from, for example, turbine exhaust steam without changing the steam temperature. The steam passes over tube bundles through which water flows. Heat from the steam is conducted through the tubes to the water which carries the heat away.

Conductor grip means a device designed to permit the pulling of conductor without splicing on fittings, eyes, etc. It permits the pulling of a continuous conductor where threading is not possible. The design of these grips vary considerably.

Current transformer means an instrument transformer intended of have its primary winding connected in series with the conductor carrying the current to be measured or controlled.

Dead end is the end of an electric wire or cable which may or may not be energized.

Dielectric means a medium in which it is possible to maintain an electric field with little or no supply of energy. Examples of dielectric materials are air, teflon, paper, Bakelite and ceramic (electrolyte type).

Dielectric Strength means the maximum potential gradient a dielectric material can withstand without breakdown, that is, becoming a conductor.

Drawhead means the body of an automatic coupler used to connect railroad (coal and ash carrying) cars and locomotives. (See Knuckle.)

Dropline means a vertical lifeline.

Drop starting means starting a portable saw by holding the saw away from the body in one hand and with no other means of support, pulling the starting cord (rope) with the other hand.

Elasticity of synthetic rope means the ratio of ["A" minus "B"] to "B" where:

1. "A" equals the elongated length of the rope when fully supporting the load
2. "B" equals the stretched full length of the rope before supporting any of the load.
3. Rope length is measured from the anchor connection to the safety belt or harness connection.
4. The load is the combined tool and body weight of the climber.

Electric generators are machines which convert mechanical power into electric power; whereas, electric motors are machines which convert electric power into mechanical power.

Electromagnetic radiation means the flow of energy consisting of orthogonally vibrating electric and magnetic fields lying transverse to the direction of propagation. X-rays, ultraviolet, visible, infrared, and radio waves occupy various portions of the electromagnetic spectrum and differ only in frequency and wavelength .

Electromagnetic wave means a wave characterized by variations of electric and magnetic fields.

Electrostatic shielding is a ground wire or static wire mounted above and strung along the line conductors, in similar fashion to the line conductors, to protect or shield the circuit from lightning.

Empirically determined means determined by ". . . experience or observation alone often without due regard for system and theory."

Employee Proficiency means that the employee, through training required by 1910.269(a) (2), has the knowledge and skills necessary to perform work practices mandated by 1910.269 in a safe manner .

Energized means connected to an energy source or containing residual or stored energy when used in 1910.269(d); otherwise the definition of energized in 1910.269(x) applies.

Equipotential zone means a three dimensional space in which temporary protective grounds are placed (located and arranged) to eliminate hazardous step potentials and touch potentials (See definitions in Appendix C II B of the standard).

Exciter means the source of all or part of the field current for the excitation of an electric machine.

Note: Familiar sources include direct-current commutator machines; alternating-current generators whose output is rectified; and batteries. (See ANSI/IEEE Std. 100 -1988, IEEE Standard Dictionary of Electrical and Electronic Terms for other definitions of exciter).

Exothermic means a chemical reaction that releases energy, for example, heat. Oxidation and Reduction Chemical reactions are exothermic. For example, Sodium (Na) atoms combined with Chlorine (Cl₂) molecules react to form salt (NaCl) and emit heat by the following equation: $2\text{Na} + \text{Cl}_2 - 2\text{Na}^+ (\text{reducing agent}) + 2\text{Cl}^-$.

Expulsion-type fuse means a vented fuse in which the explosive effect of gases produced by the arc or burning of the fuse holder, either alone or aided by a spring, extinguishes the arc. The arc erodes the tube of the fuse holder, producing a gas that ignites causing an explosion that blasts the arc out through the fuse tube vent(s) and thereby opens the circuit.

Extra high voltage (EHV) is defined as voltage levels higher than 240,000 volts.

Fault means a partial or total local failure in the insulation or continuity of a conductor. (See ANSI/IEEE Std.100-1988, Standard Dictionary of Electrical and Electronic Terms for other definitions used in electric power generation, transmission and distribution.)

Flashover (gap sparkover) voltage means a disruptive discharge through air around or over the surface of solid or liquid insulation, between parts of different potential or polarity, produced by the application of voltage wherein the breakdown path becomes sufficiently ionized to maintain an electric arc.

Flume means an artificial channel or chute which transports and directs the flow of water, for example, to the hydroelectric turbine. Flumes may be open or closed. A canal is an example of an open flume and a penstock in an example of a closed flume.

Forced air ventilation means mechanical ventilation such as a permanent or portable blower (as opposed to natural ventilation).

Forebay is an open basin, that is, a small reservoir to take care of variations in water flow demand at the turbine. A forebay is located between the canal on the upper end and the penstock on the lower end of a hydroelectric power plant installation which directs water from the upper reservoir to the hydraulic turbine below.

Free-fall means the act of falling before the personal fall arrest system begins to apply force to arrest the fall.

Gaff means the metal spur part of climbers. The gaff is attached to the bottom of the hook stem and protrudes toward the other foot. (See Climbers.)

Gap means the clear air space between objects.

Hazardous energy means a voltage at which there is sufficient energy to cause injury. If no precautions are taken to protect employees from hazards associated with involuntary reactions from electric shock, a hazard is presumed to exist if the induced voltage is sufficient to pass a current of 1 milliamperes through a 500 ohm resistor. (The 500 ohm resistor represents the resistance of an employee. The 1 milliamperes current is the threshold of perception.) If employees are protected from injury due to involuntary reactions from electric shock, a hazard is presumed to exist if the resultant current would be more than 6 milliamperes (the let-go threshold for women).

Hazardous (induced) voltage means 50 (rms) volts or more.

High power testing involves sources where fault currents, load currents, magnetizing currents, or line dropping currents are used for testing, either at the rated voltage of the equipment under test or at lower voltages.

Impedance (z) is the ratio of voltage to current expressed in complex terms. It represents the opposition that a circuit offers to A.C. current. $z = v \div i$ measured in ohms where v = voltage and i = current. (See ANSI/IEEE Std. 106-1988 , IEEE Standard Dictionary of Electrical and Electronic Terms for other definitions used in electric power generation, transmission and distribution).

Induced voltage mean a voltage produced around a closed path or circuit by a change in magnetic flux linking that path. (See ANSI/IEEE Std. 100-1988, IEEE Standard Dictionary of Electrical and Electronic Terms for other definitions used in electric power generation, transmission and distribution.)

Inextricably commingled refers to electrical components of the power generation, distribution and transmission systems and the utilization systems in an electric power generation, substation or other facility such that the components are mixed (interconnected) so that they are indistinguishably tied together.

Jumper means a short length of cable used to make electric connections within, between, among, and around circuits and their associated equipment

Note: It is usually a temporary connection.

Knuckle means the movable arm which connects with the drawhead to form the coupling on cars and locomotives. (See Drawhead.)

Laser means Light Amplification by Stimulated Emission of Radiation. Any of several devices that convert incident electromagnetic radiation of mixed frequencies to one or more discrete frequencies of highly amplified and coherent radiation may be called a laser.

Line Insulator is a device which prevents the flow of an electric current by direct contact or flashover and is used to support electrical conductors. A function of an insulator is to separate the energized conductors from the poles or towers. Insulators are fabricated from porcelain, glass, clay and fiberglass. (See ANSI/IEEE Std. 100-1988, IEEE Standard Dictionary Of Electrical and Electronic Terms for other descriptions and definitions of "insulator").

Live-line bare-hand work (technique) means work performed by a qualified employee or person in an Equipotential zone established at the potential of a line conductor.

Live line tool rods, tubes, and poles (hot sticks) are insulating tools used by employees to perform live line servicing and maintenance. These tools insulate the employee from an energized part and enable the employee to work a safe distance from an energized part.

Loadline means a rope or line which bears the weight of a mass, for example, a tower or a tower section during erection or removal.

Maximum rated operating pressure means the maximum operating pressure for which a hydraulic or pneumatic tool is designed and built by the manufacturer and identified on the nameplates of these tools.

Maximum rated load (or load rating) means the maximum applied load for which the mechanical equipment is designed and built by the manufacturer and identified-on the nameplate of the equipment.

Metering (meter installation inspection): Examination of the meter, auxiliary devices, connections, and surrounding conditions, for the purpose of discovering mechanical defects or conditions that are likely to be detrimental to the accuracy of the installation. Such an examination may or may not include an approximate determination of the percentage registration of the meter.

Microwave (data transmission). A term used rather loosely to signify radio waves in the frequency range from about 1000 megahertz (MHZ) upwards. Microwave radio signals are used for point to point communication between substations and other power system facilities and specifically, for communication channels, protective relaying, supervisory control and remote metering.

Normal (Gaussian) distribution is a continuous probability distribution which is defined by

$$f(x) = \frac{1}{\sigma \sqrt{2\pi}} e^{-1/2(x-\mu)^2/\sigma^2}$$

The standard normal distribution or curve is obtained by substituting $t = x-\mu$ into $f(x)$ above or

$$\Phi(t) = \frac{1}{\sqrt{2\pi}} e^{-1/2t^2}$$

which has a mean, $\sigma=0$ and a variance, $\text{Var}=\sigma^2=1$

The above normal (Gaussian) distribution curve is a bell-shaped curve which is symmetrical about the positive y-axis (at which $\Phi(t)$ has its maximum value) of an x-y graph. The ends of the curve approach the x-axis as x increases and as -x decreases.

In one standard deviation ($\sigma=1$), there is 68.2% of the area under the curve, that is, there is a 68.2% probability that the random variable lies within one standard deviation. Likewise, there is a 95.4% and 99.6% probability within $\sigma=2$ and $\sigma=3$, respectively.

Open circuit means a break in the circuit so that a complete conductive path is not provided for current to flow.

Overhead lines means electric transmission or distribution line conductors installed overhead either underground or above ground inside or outside of a building.

Overvoltage means a voltage above the normal rated voltage or the maximum operating voltage of a device or circuit. (See ANSI/IEEE Std. 100-1983, IBEE Standard Dictionary of Electrical and Electronic Terms for other definitions of overvoltage used in electric power generation, transmission and distribution.

Parallel circuit means a circuit in which two or more (for example, resistor) components are connected across the same voltage source.

Partial vacuum means the pressure inside a vessel is less than the atmospheric pressure surrounding the vessel.

Penstock is the closed conduit which transports water at the upper reservoir level to the (tail-water reservoir) level below at a hydroelectric power plant. A penstock is located between a forebay at the end of the canal on the upper level and a hydraulic turbine in the powerhouse on the lower level.

Personal fall arrest equipment consists of a body belt or body harness, connectors and may include a lanyard, deceleration device, lifeline or suitable combination.

Personal fall arrest system means a system used to arrest an employee in a fall from a working level. It consists of an anchorage and personal fall arrest equipment.

Phase-to-ground voltage means the voltage measured by a voltmeter between a conducting transmission line and a ground wire, for example the electrostatic shielding conductor to the ground (earth).

Phase-to-Phase voltage means the voltage measured by a voltmeter between conducting transmission lines.

Phasing out means live-line maintenance to determine whether the phase of a given electric line (or apparatus) corresponds with the phases of another line (or apparatus) when a new line is to be paralleled with another line, new or old, and after repairs or changes have been made on either of two lines which have previously operated in parallel. When a phasing out voltmeter, connected across corresponding lines or phases reads zero voltage, the phases of the two lines are properly installed in phase.

Power line carrier means the use of radio frequency energy, generally below 600 kHz, to transmit information over transmission lines whose primary purpose is the transmission of electric power.

Pull rig means a rig used to install or remove a line conductor. The pull rig consists of a take-up reel and carriage, a pulling rope and a puller.

Relaying means remote operation of electric control relays by microwave radio signals, by power line carrier signal, or by pilot wire communications.

Resistance (r) means that physical property of an element, device, branch, network, or system that is the factor by which the mean-square conduction current must be multiplied to give the corresponding power lost by dissipation as heat or as other permanent radiation or loss of electromagnetic energy from the circuit. In short, resistance means the opposition to current flow.

RMS stands for root mean square and is the square root of the average square of the instantaneous magnitude of the voltage or current taken throughout one period. A RMS value is the effective value. Effective values are specific values of voltages and current to which time varying, periodic (alternating) voltages and currents (AC) are associated. By definition, the effective value of a periodic direct voltage and current, V_{eff} and I_{eff} respectively, is the positive direct voltage and current (DC) that produces the same average power (P_{av}) in a resistor (R) or $P_{\text{av}} = V_{\text{eff}}^2/R$ and $P_{\text{av}} = I_{\text{eff}}^2R$.

Note: Electric appliances are rated in effective (RMS) values. Also, most AC ammeters and voltmeters give readings in effective values.

Example of how to calculate RMS values.

For a sinusoidal voltage, the average power loss is

$$P_{\text{av}} = V_m^2/2R \text{ where } V_m \text{ is the peak value of the sinusoidal voltage.}$$

$$\text{Then } P_{\text{av}} = V_{\text{eff}}^2 / R = V_m^2 / 2R \text{ and } V_{\text{eff}} = V_m / \sqrt{2} = 0.707 V_m$$

Summarizing, the effective voltage (V_{eff}) equals 0.707 times the peak voltage: (V_m) of the sinusoidal at voltage.

A similar calculation yields: $I_{\text{eff}} = I_m / \sqrt{2} = 0.707 I_m$

Note: Different periodic (alternating) voltages and currents have different effective values. For example, a saw tooth (or triangular wave) has effective values equal to the peak values divided by $\sqrt{3}$. Effective values must be calculated (using calculus) for each different periodic wave configuration.

Safety (climber's) saddle means a body sling to which the climbing rope is secured. The safety saddle fits around the lower buttock of the climber and is secured by a taut-line hitch to a snap, front and center on the safety saddle approximately opposite the climber's belly button.

Safety strap means a strap used to support employees in a working position on poles, towers and platforms. Integral snaphooks on each end of the strap connect to different D-rings of a body belt. The strap is adjustable for length by means of a buckle in the strap to suit the workman and the support, for example, the pole, it fits around.

Series circuit means a circuit in which there is only one path for current to flow along.

Short circuit is an abnormal connection (including an arc) of relatively low impedance, whether made accidentally or intentionally, between two points of different potential. (See ANSI/IEEE Std. 100-1988, IEEE Standard Dictionary of Electrical and Electronic Terms for more specific definitions.)

Skirt (petticoat) means the outer skirt-like portion of a line insulator.

Snaphook means a connector comprised of a hook-shaped member with a normally closed keeper, or similar arrangement, which may be opened to permit the hook to receive an object and when released, automatically closes to retain the object. Snaphooks are generally one of two types:

1. The locking type with a self-closing, self locking keeper which remains closed and locked until unlocked and pressed open for connection or disconnection, or
2. The non-locking type with a self-closing keeper, which remains closed until pressed open for connection or de-connection.

Standard deviation (σ) means the square root of variance (Var) which measures the spread or dispersion of a random variable (x) with respect to the mean (μ) or expected value. Where,

$$\mu = \sum_{-\infty}^{\infty} x f(x) dx$$

Stored energy means residual mechanical, thermal or electrical energy possessed by a machine or equipment after powering and controlling energy source(s) have been isolated. Also, electrical stored energy (W) mean the electromagnetic energy and the electrostatic energy stored in a transmission line at any instant or $W=1/2Li^2+1/2Ce^2$ where, C is capacitance, L is inductance, and i and e are instantaneous current and voltage, respectively.

Stringing (pilot line) means a light weight rope used to pull the pulling rope to which a line conductor is attached typically for pole installation through the stringing blocks of travelers.

Stringing sheave means a sheave which is used to redirect the travel of a line conductor during its installation or removal. The sheave is mounted on a string block attached to a supporting (pole, tower) structure.

Stringing sock or board means a device which is used to pull multiple line conductors simultaneously by one pulling line.

String insulators means multiple insulators mounted one upon the other to provide the required spread distance between the line conductors and pole or tower supporting components. The number of insulator units in a string depend largely on the voltage of the line, that is, the higher the voltage the more insulator units in a string.

Substation means a high-voltage electric system facility used to switch generators, equipment, and circuits or lines in and out of the system, change A.C. voltages from one level to another, and/or change A.C. to D.C. or D.C. to A.C. (See ANSI/IEEE Std. 100-1988, IEEE Standard Dictionary of Electrical and Electronic terms for other specific substation definitions.)

Surge arrester means a device that prevents high voltages (over voltages) from building up on a circuit by discharging or by passing surge current from lightning or transient voltages and then restores normal circuit conditions. (See ANSI/IEEE Std. 100-1988, IEEE Standard Dictionary of Electrical and Electronic Terms for specific application definitions.)

Surge (transients) means a transient wave of current, potential, or power in an electric circuit. Surges can be caused by direct lightning strokes or induced charges as a result of lightning strokes to ground or can be caused by circuit-switching operations as well as the operation of devices connected to the lines.

Switching surge means transient voltage (overvoltage) caused by opening, closing or short circuiting an electrical system. (See ANSI/IEEE Std. 100-1988, IEEE Standard Dictionary of Electrical and Electronic Terms for specific application definitions.)

Taps means connecting de-energized conductors to live lines by special live (hot) line tapping clamps. (See ANSI/IEEE Std. 100- 1988, IEEE Standard Dictionary of Electrical and Electronic Terms.)

Tension stringing means the use of pullers and tensioners to keep the conductor under tension and positive control during the stringing phase, thus keeping it clear of the earth and other obstacles which could cause damage

Test observer means an employee who guards a high-voltage or high-power testing area to prevent unauthorized entry.

Tied-in means an employee wearing a body belt or safety strap is connected to the work positioning equipment including a climbing rope and safety saddle.

Transformer is an electromagnetic device having two or more stationary coils coupled through a mutual flux. Basic components of a transformer are the core and primary and secondary coils (windings). These coils are electrically insulated from each other. Electric energy is transferred from one coil to the other coil using magnetic coupling. The coil receiving energy from an A.C.

source is called the primary and the coil delivering energy to the A.C. load is called the secondary. (See ANSI/IEEE Std. 100-1988, IEEE Standard Dictionary of Electrical and Electronic Terms for specific application definitions.)

Transient voltage means overvoltage or undervoltage with respect to steady state voltage.

Voltage Regulator means a device which maintains constant voltage. A voltage regulator is used to vary alternating current (AC) supply or source voltage to keep the voltage within the limits desired.

Waveguide means a system of material boundaries or structures, for example, a hollow cylinder (circular cross section) made of a good conducting material, for guiding electromagnetic waves. Waveguides are used to transfer very high frequency energy at high power levels from place to place. Energy conveyed by the waveguide is contained in the electric and magnetic fields established within the guide.

Web-type lanyard means a strap of woven synthetic fibers.

Work-positioning equipment means equipment used in a positioning device system which is used by an employee for support in an elevated position on a vertical object, for example, a power pole, or on a vertical surface, for example the side of a building, so that both hands are free to perform work.

Appendix B

CLARIFICATION OF MAJOR ISSUES

1. Generation or transmission: 1910.269(d) and (m)

Electric power generation plants typically have the electrical output of the generators feeding a substation. The generating plant substation, in turn, steps up the voltage and supplies a transmission line. Thus, the question arises as to where generation stops and transmission begins.

Section 1910.269 does not define "generation", "transmission", or "distribution". Generally, with respect to the application of 1910.269, the distinction between transmission and distribution is immaterial. The same rules apply to both systems. However, lockout and tagging of electrical power in installations for the generation of electric power is covered under paragraph (d), whereas the de-energizing of transmission and distribution lines is covered under paragraph (m). Therefore, the distinction between "generation" and "transmission and distribution" is important in the application of 1910.269.

It is common for electric utilities to consider everything on the load side¹ of the disconnects for the output side of the generator step-up transformers to be part of the transmission system, and for everything else in the substation, including the electrical installation back to the generator, to be part of the generating installation. However, some utilities (and many industrial generators) treat everything from the load side of the disconnect for the generator as transmission (or, in the case of industrial generators, in-plant distribution). In such cases, everything within the substation is considered to be part of the transmission system.

With respect to electrical systems that might become energized during the course of work, OR- OSHA considers paragraph (m) to provide the same level of protection to employees provided by paragraph (d). Under paragraph (m), normally energized equipment is not to be treated as de-energized until after disconnects have been opened and after tags and protective grounds have been applied. The protective grounds (which must meet the requirements of paragraph (n)) ensure the safety of employees in case the system accidentally becomes energized. Paragraph (d), on the other hand, is intended to prevent the release of potentially

¹ The "load side" of a disconnect is the portion of the circuit that is de-energized when the disconnect is open. It includes parts of the disconnect that also become de-energized when it is open. In the networked type of installation used by electric utilities, the "load side" might be energized through downstream sources of electric power. However, for the purposes of this definition (as applied in a generating station), these downstream sources should be ignored.

hazardous energy while maintenance and servicing activities are being performed. Within certain limitations,² both paragraphs provide equivalent protection to employees.

For the purpose of training employees in a single set of procedures for de-energizing electric equipment at a generating plant, employers may wish to designate certain portions of the transmission system as "generation", or to designate certain portions of the generation system as "transmission." At a generating station, OR-OSHA will accept an employer's determination of what is considered to be generation and what is considered to be transmission or distribution under the following conditions:

The demarcation of where the transmission (or distribution) system begins lies somewhere between the load side of the generator disconnects and the load side of the disconnects for the output side of the generator step-up transformers, inclusive of those points;

1. The employer has clearly identified this demarcation point in the hazardous energy control program;
2. Unqualified employees do not have access to the disconnects or to protective grounds for the transmission system;
3. Hazards posed by non-electrical energy sources are addressed by the employer's hazardous energy control program under paragraph (d); and
4. Affected employees are trained in the interface between the generation system and the transmission system within the associated hazardous energy control procedures.

2. Retrofitting Of machines or equipment to accept locks: 1910.269(d)(2)(ii)(C)

Existing controls in electric power generating stations are not always designed to accept a lock. Paragraph (d)(2)(ii)(C) of 1910.269 requires any controls that are "energy isolating devices" to be replaced with devices that will accept locks whenever a machine or equipment is replaced and whenever major repair, renovation, or modification of a machine or equipment is performed. To meet this requirement, an employer may fabricate adapters that enable the energy isolating devices to accept a lock. Energy isolating devices for which adapters have been fabricated meet 1910.269(d)(2)(ii)(C) provided:

² Paragraph (d) does not provide complete protection when an electrical system may become energized from sources outside of the electric circuit involved. For example, transmission and distribution lines can be energized by lightning or by contact with another circuit (as when one distribution line falls onto another). Paragraph (m) does not provide complete protection: (1) when unqualified employees have access to electrical disconnecting means and to protective grounds or (2) when many independent crews each have to apply individual protective grounds at a single point or (3) when non-electrical sources of energy pose hazards to employees.

- 1) The adapters meet the requirements for tagout device attachment means contained in 1910.269(d)(3)(ii)(D), except that the adapter may be reusable;
 - 2) The adapters are used when the energy isolating device is locked out or tagged out;
 - 3) The adapters can accommodate a lock;
 - 4) The adapters are designed to prevent the operation of the energy isolating device when a lockout device is attached; and
 - 5) The energy isolating device itself is not being replaced, or, if it is, it cannot be replaced with one that will accept a lock without replacing other unaffected energy isolating devices or the equipment that it isolates.
3. Strength of attachment device: 1910.269(d)(3)(ii)(D)
23. Paragraph (d)(3)(ii)(D) of 1910.269 requires tag attachment means to have an unlocking strength of at least 50 pounds. This requirement is based on the specified strength of a standard 1/4-inch nylon cable tie.³ In some cases, this size cable tie is too large to fit through the tag attachment fitting on the energy isolating device. OR-OSHA will consider the use of a tagout device attachment means that does not meet the 50-pound unlocking strength requirement of(d)(3)(ii)(D) as a minimal violation provided:
- 1) The point of attachment for the energy isolating device will not accept a 1/4-inch cable tie;
 - 2) The tagout device attachment means is as strong as permitted by the point of attachment (for example, the largest size cable tie that will fit through the point of attachment is used);
 - 3) The tagout device attachment means is strong enough and is attached in such a manner as to prevent inadvertent operation of the energy isolating device; and
 - 4) The tagout device and its attachment means otherwise meet the requirements of 1910.269(d)(3)(ii)(D).
4. Employees placing lockout or tagout devices, group lockout/tagout and master tagging programs: 1910.269(d)(4), (d)(6), (d)(7), and (d)(8)(ii)

³A 1/4-inch cable tie has a published unlocking strength of about 75 pounds. Section 1910.147 (on which 1910-269 is based) adopted a 50-pound unlocking strength criterion to allow a smaller cable tie or one with a lower strength.

With the exception of paragraph (d)(8)(v), 1910.269(d) was taken directly from the generic standard for the control of hazardous energy sources, 1910.147. The program directive on 1910.147,⁴ the generic lockout/tagout standard, contains guidance for the use of group lockout/tagout and master tagging programs. Appendix C of that directive presents example group lockout/tagout procedures⁵ that can be used to comply with 1910.269(d).

5. Outside rescue services: 1910.269(e)(3)

Paragraph (e)(3) of 1910.269 requires employers to "provide equipment to ensure the prompt and safe rescue of employees" from enclosed spaces.

Enclosed spaces are, by definition, also permit-required confined spaces under 1910.146, the generic confined spaces standard. During electric power generation, transmission, and distribution work, enclosed spaces may be entered by qualified employees under the procedures set out in 1910.269(e) and (t) rather than those specified by 1910.146(d) through (k). However, if the hazards remaining in the space after the procedures required by 1910.269(e) and (t) are followed endanger the life of the entrant or could interfere with escape from the space, then the entry must conform to paragraphs (d) through (k) of 1910.146. Because of the possibility that an enclosed space will have to be entered as a permit space under 1910.146, employers will necessarily plan their enclosed space entry procedures taking both standards into consideration.

If the need for rescue from the space arises, two possible scenarios will be present. In the first scenario, the space would continue to be an enclosed space; no actual atmospheric hazard would be present; and entry could continue under 1910.269. In the second scenario, the space would no longer be an enclosed space, and the full permit-entry procedures required by 1910.146 would have to be followed.

In the first scenario, the attendant could summon rescue services, enter the enclosed space, and administer first aid. For example, the entrant could suffer an electric shock. The attendant would first summon a rescue service and then check the atmosphere and other conditions in the space to ensure that it is still safe to enter. The attendant could subsequently enter the space to administer first aid and cardio-pulmonary resuscitation, if necessary, to the injured entrant. In this scenario, the need to remove the entrant from the space will not arise until the rescue service arrives to treat the injured employee further and transport him or her to the hospital.

In the second scenario, the attendant would be prohibited from entering the space by 1910.146. Unless a non-entry retrieval system was in place, the injured employee could not be removed from the space until the rescue service arrives.

⁴OSHA Instruction STI) 1-7.3.

⁵These are intended its examples only. Other means of meeting the standard may also be used.

Under either scenario, an injured entrant would not be removed from the enclosed space until rescue services arrive. Additionally, many rescue services will use their own rescue equipment rather than that provided by an employer. For these reasons, OR-OSHA will accept an employer's reliance on rescue equipment owned by rescue services for the purpose of compliance with 1910.269(e)(3) under the following conditions:

- 1) The employer complies with 1910.146(d)(4)(viii), (d)(9), and (k);
- 2) The employer has evaluated a rescue service, has determined that it has the necessary rescue equipment, and can demonstrate that the service can provide for prompt and safe rescue of employees from enclosed spaces;
- 3) The employer arranges with this rescue service to provide for prompt and safe rescue of employees from enclosed spaces; and
- 4) The employer provides such additional rescue equipment as the rescue service needs to provide for prompt and safe rescue of employees from enclosed spaces.⁶

6. Tagging network protectors: 1910.262(m)(3)(ii) and(iii)

Paragraph (m)(3)(ii) of §1910.269 requires all switches, disconnections, jumpers, taps, and other means through which known sources of electric energy may be supplied to the particular lines and equipment to be de-energized to be opened and tagged, Paragraph (m)(3)(iii) requires automatically and remotely controlled switches to be tagged at the point of control.

An ac network system consists of feeders, step-down transformers, automatic reverse current trip breakers called network protectors, and the network grid of street mains. The network grid is made up of a number of single conductor cables tied together at street intersections to form a solid grid over the area they serve. This grid is typically energized at 120/208 volts from the secondary windings of the distribution transformers serving a particular area. A network protector, placed between the secondary side of the transformer and the secondary mains, is provided for each transformer. The primary windings of the transformer are connected to a feeder cable that is energized from a substation at voltages ranging from 13 to 33 kilovolts. Each feeder cable is connected to the substation through an automatic circuit breaker. See Figure 1.

Network protectors are placed between the network transformer and the secondary network

⁶The employer will normally need to supply such personal rescue equipment as harnesses and retrieval lines, as well as first aid kits. The rescue service will normally provide mechanical lifting devices and initial response medical equipment. This will usually provide for the safest, quickest, and most effective rescues. However, if the employees will enter enclosed spaces that present obstacles to the effective use of the rescue service's normal equipment, the employer will have to supply rescue equipment that meets the particular needs of such spaces.

to protect against reverse power flow through the network transformer into the supply feeders. Reverse power protection is necessary because fault current would continue to flow into a short circuit in a network transformer or primary feeder. Backfeed from the network grid would continue to flow into the fault even after the primary feeder circuit breaker trips. The other primary feeders would continue to supply power to their network transformers, which are interconnected with the faulted circuit through the network grid.

Under normal conditions, switches at the substation are used to de-energize the primary conductors to the distribution transformers. When the primary conductors become de-energized, the network protectors operate to disconnect the secondary side of the transformers and to prevent backfeed from energizing the primary conductors. The network protectors are automatic devices and are not normally opened or closed manually.

Not tagging a network protector for work on the primary feeder to its associated network transformer is considered a minimal violation of 1910.269(m)(3)(ii) under the following conditions:

- 1) The line is de-energized as otherwise required by paragraph (m)(3)(ii);
- 2) Any switches or disconnecting means (other than network protectors) used to de-energize the line are tagged as required by paragraph (m)(3)(ii);
- 3) The line is tested to ensure that it is de-energized as required by paragraph (m)(3)(v);
- 4) Grounds are installed as required by paragraph (m)(3)(vi);
- 5) The network protectors are maintained so that they will immediately trip open if closed when a primary conductor is de-energized;
- 6) The network protector cannot be manually placed in a closed position without the use of tools, and any manual override position must be blocked, locked, or otherwise disabled; and
- 7) The employer has procedures for manually overriding the network protector that incorporate provisions for ensuring that the primary conductors are energized before the protector is placed in a closed position and for determining if the line is de-energized for the protection of employees working on the line.

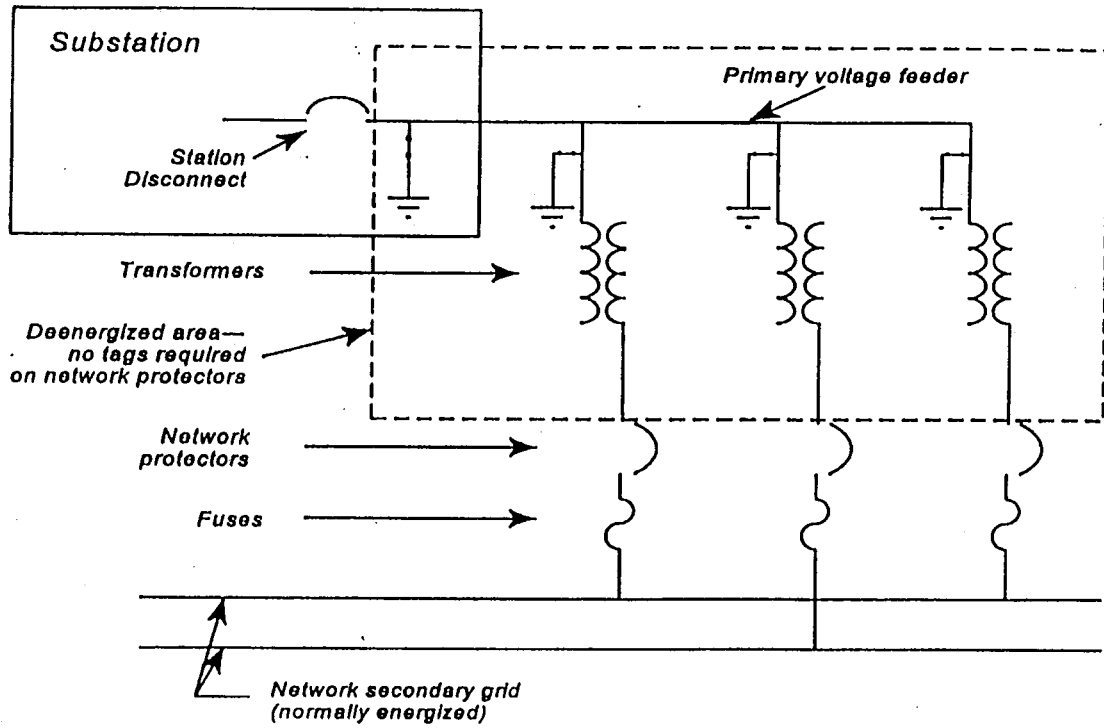

Figure 6—Network Protectors

7. Application of grounding requirements to lines and equipment rated at 600 volts or less: 1910.269(n)(1), (n)(4)

Paragraph (n)(1) of 1910.269 applies the grounding requirements of paragraph (n) to electric power transmission and distribution lines and equipment, regardless of voltage. Lines and equipment operating at 600 volts or less present certain problems with respect to compliance with paragraphs (n)(4)(i) and (n)(4)(ii).

Paragraph (n)(4)(i) requires protective grounding to be capable of conducting the maximum fault current that could flow at the point of grounding for the time necessary to clear the fault. The maximum fault current on electric power distribution lines operating at 600 volts or less is typically high enough to melt the phase conductors carrying the fault current.⁷ If protective grounding equipment were required to carry the maximum amount of fault current without regard to whether the phase conductors would fail, the size of the grounding equipment would be impractical. However, the standard does not require the protective grounding equipment to be capable of carrying more current than necessary to allow the phase conductors to fail. Thus, a protective grounding jumper sized slightly larger than a phase conductor would be sufficient to meet paragraph (n)(4)(i).⁸

Paragraph (n)(4)(ii) requires protective grounding equipment to have an impedance low enough to cause immediate operation of protective devices in case of accidental energizing of the lines or equipment. This requirement is intended to ensure that the protective grounding equipment itself does not contribute to any delay in the operation of the devices protecting the circuit. For lines and equipment operating at 600 volts or less, the design of the system allows some ground faults to occur without the operation of the circuit protection devices regardless of the impedance of the grounding equipment. However, if the impedance of the grounding equipment does not contribute to delay in the operation of the circuit protection devices and if the impedance of this equipment is low enough to provide a safe work zone for employees (as required by paragraph (n)(3)), the employer will be in compliance with paragraph (n)(4)(ii).

8. Temporary protective grounds: 1910.269(n)(3)

Paragraph (n)(3) of 1910.269 requires "temporary protective grounds" to be placed at such locations and arranged in such a manner as to prevent each employee from being exposed to hazardous differences in electrical potential. The word "temporary" in this requirement refers to the fact that the grounds are applied temporarily, while employees are working.

⁷Available fault currents on 600-volt systems may be in the range of 13,000 to 80,000 amperes.

⁸While it is possible for the phase conductor to fail at a point that allows the line or equipment on which the employee is working to remain energized after the failure, judicious placement of protective grounds can minimize this possibility.

Temporary protective grounds may include fixed as well as portable grounds, provided the fixed grounds meet the following conditions:

- 1) Enclosed switches that apply the grounds have a -visible indicator to show when ground has been applied; and
- 2) The grounds are inspected and maintained to ensure that they are fully operational.

9. Testing for absence of nominal voltage: 1910.269(n)(5)

Paragraph (n)(5) of 1910.269 requires lines and equipment to be tested for the absence of nominal voltage before any ground is installed. Some fixed grounding devices have handles that operate grounding switches from a remote position. These devices typically isolate employees from hazards associated with installing a ground on an energized line. An employer would not be in violation of Paragraph (n)(5) even though a test for the presence of nominal voltage is not performed under the following conditions:

- 1) If grounds are installed through the use of fixed grounding switches; and
- 2) If the employee operates the switch from a remote position where no one will be exposed to the hazards of applying a ground to energized lines or equipment.⁹
In this case, there would not be a violation since no employee would be exposed to the hazards regulated by the standard.

10. Grounding at remote cable terminals: 1910.269(n)(8)

Paragraph (n)(8) of 1910.269 reads as follows:

When work is performed on a cable at a location remote from the cable terminal, the cable may not be grounded at the cable terminal if there is a possibility of hazardous transfer of potential should a fault occur. (Emphasis added.)

Under line-to-ground fault conditions (as would happen if a cable were accidentally reenergized while it was grounded), the difference in potential between the conductor and the ground varies from point to point along the conductor. If the cable is grounded at a location remote from where the work is being performed, the potential on the conductor at the work location would be higher than it would be at the grounding location. The design of

⁹Because of the possibility that the lines or equipment may be energized, these hazards include:

- Hazards related to the rise in step and touch potentials;
- Hazards related to electric arcs; and
- Hazards associated with the mechanical forces that can be generated by fault current.

the system and the location of the ground with respect to the work will determine whether or not the potential at the work location, under worst case conditions, will be high enough to pose a hazard to the employees working on the cable.

Paragraph (n)(8) is not intended as a general prohibition on grounding an underground cable at remote terminals (such as the source station). In fact, it is common industry practice to require station grounds for the protection of employees when work is performed on underground cable systems. Only when the hazard of having the grounds in place exceeds that of omitting the remote grounds is remote terminal grounding prohibited.¹⁰

11. Visible grounds; 1910.269(o)(4)(ii)

Paragraph (o)(4)(ii) of 1910.269 requires the application of visible grounds to high voltage circuits after they are de-energized and before work is performed on the circuit. Protective grounds required by paragraph (o)(4)(ii) may include fixed as well as portable grounds, provided the fixed grounds meet the following conditions:

- 1) Enclosed switches that apply the grounds have a visible indicator to show when the ground has been applied; and
- 2) The grounds are inspected and maintained to ensure that they are fully operational.

12. Line-clearance tree trimming in bad weather: 1910,269(r)(1)(vi)

Paragraph (r)(1)(vi) of 1910.269 prohibits line-clearance tree trimmers¹¹ from performing line-clearance tree-trimming work when adverse weather conditions make the work hazardous in spite of the work practices required by 1910.269. The note following this paragraph describes the types of weather conditions intended to trigger this prohibition. Work in less severe weather conditions, including rain or drizzle (unless accompanied by high winds, by freezing conditions, or by thunder and lightning), is not prohibited by paragraph (r)(1)(vi). Additionally, tree trimming work is not prohibited if all electric power lines in the area to be cleared have been de-energized under 1910.269(m).

13. Access by unqualified persons to areas containing unguarded energized parts; 1910.269(u)(4) and (v)(4)

Electric power generating stations and transmission and distribution substations typically have areas containing energized electric lines and equipment. Unless the energized lines or

¹⁰See 1910.269(n)(3) for further requirements protecting employees from hazardous differences in potential.

¹¹This paragraph does not apply to qualified employees performing line-clearance tree-trimming work.

equipment are guarded sufficiently, it is unsafe for unqualified persons to enter these spaces. Paragraphs (u)(4)(i)(A) through (C) and paragraphs (v)(4)(i)(A) through (C) set requirements for spaces within substations and generating stations, respectively, that are acceptable for unqualified persons to enter. Under 1910.269(u)(4)(ii) through (v) and (v)(4)(ii) through (v), areas not meeting these requirements are restricted from entry by unqualified persons.

Employers may train employees as qualified employees for the purposes of entering and working within restricted areas of generating stations and substations. While the training for these employees must meet 1910.269(a)(2)(ii), it need not be as comprehensive as the training normally provided to a qualified electrical worker.¹² These "qualified" (non-electrical) employees must have the following minimum training:

- 1) They must know what is safe to touch and what is not safe to touch in the specific areas they will be entering (paragraph (a)(2)(ii)(A));
- 2) They must know what the maximum voltage of the area is (paragraph (a)(2)(ii)(B));
- 3) They must know the minimum approach distances for the maximum voltage within the area (paragraph (a)(2)(ii)(C); and
- 4) They must be trained in the recognition and proper use of protective equipment that will be used to provide protection for them¹³ and in the work practices necessary for performing their specific work assignments within the area (paragraph (a)(2)(ii)(D).

Until these "qualified employees" have demonstrated proficiency in the work practices involved, they are considered to be employees undergoing on-the-job training and must be under the direct supervision of a qualified employee at all times.¹⁴ (See the definition of "qualified employee" in 1910.269(x)).

Rescue services and fire departments might have to enter restricted areas under emergency conditions. In such cases, where there would be a greater hazard if the rescue service or fire department personnel could not enter, a minimal violation is considered

¹²A qualified electrical worker normally undergoes a multi-year apprenticeship training program before he or she becomes fully qualified to perform all the different types of work that he or she would be expected to perform this training includes not only the safety aspects of working on or near exposed energized circuit parts, it includes training in the actual performance of specific tasks so that work is of an acceptable level of workmanship.

¹³Only fully qualified electrical employees may install insulating equipment on energized parts.

¹⁴According to the definition of "qualified employee," the employee must also have demonstrated an ability to perform work safely at his or her level of training. It is expected that an orientation familiarizing the employee with the safety fundamentals given here will be conducted before an employee undergoing training is allowed to enter a restricted area.

to exist if one or more qualified employees directly supervise the operation and employees involved.

14. Chlorine repair kits: 1910.269(v)(8)(iii)

Paragraph (v)(8)(iii) of 1910.269 requires emergency repair kits to be available near chlorine system shelters or enclosures for the prompt repair of leaks in chlorine lines, equipment, or containers.

Paragraph (q) of 1910.120 allows employers to evacuate his or her employees in lieu of complying with the provisions of that Paragraph provided the employer has an emergency action plan conforming to 1910.38(a). Employers who meet this exception, contained in 1910.120(q)(1), are not in violation of 1910.269(v)(8)(iii). In this case, there would be no violation since no employee would be exposed to the hazards regulated by paragraph (v)(8)(iii).

Paragraph (q) of 1910.120 also allows employers to rely on an outside hazardous materials response (HAZMAT) team to handle releases of hazardous materials (in this case, chlorine). If an employer does not evacuate his or her employees, the employer will be deemed to be in compliance with 1910.269(v)(8)(iii) even though chlorine repair kits are not available at the shelter or enclosure, provided the following conditions are met:

- 1) The employer relies on an outside HAZMAT team to respond to chlorine leaks; and
- 2) The employer complies with the applicable requirements of 1910.120(q).

15. Chlorine system purging 1910.269(v)(8)(iv)

Paragraph (v)(8)(iv) of 1910.269 requires dry air to be used to purge chlorine tanks, pipes, and equipment. The purpose of this requirement is to prevent the chlorine gas from reacting with moisture in the gas used to purge the system. The use of an inert gas for this purpose is considered to be a *de minimus* violation of this requirement, as the use of such a gas would preclude the presence of moisture.

16. Hydrogen leaks: 1910.269(v)(10)(ii)

Paragraph (v)(10)(ii) requires excessive hydrogen makeup or abnormal loss of pressure to be considered an emergency and to be corrected immediately. The presence of hydrogen in concentrations of 10 percent of the lower flammable limit outside the hydrogen system or the loss of sufficient hydrogen to create such a concentration outside the hydrogen system is considered sufficient to trigger this requirement.

17. Hazardous (classified) locations in coal-and ash-handling areas: 1210.269(v)(11)(xii)

Paragraph (v)(1)(xii) requires the control of ignition sources in coal-and ash-handling areas where a combustible atmosphere might be produced. The note following this paragraph refers to the requirements for electrical installations in hazardous (classified) locations contained in 1910.307. The note is intended as a reference only, and 1910.269(v)(11)(xii) is not intended to add to or subtract from the duties required under 1910.307 for electrical utilization installations.

Section 500-2 of the National Electric Code reads, in part, as follows:

Location and General Requirements. Locations shall be classified depending on the properties of the flammable vapors, liquids or gases, or combustible dusts or fibers that may be present and the likelihood that a flammable or combustible concentration or quantity is present....

Each room, section, or area shall be considered individually in determining its classification.

This guidance must be used in classifying possible hazardous (classified) locations for determining compliance with 1910.269(v)(11)(xii) and 1910.307.